

FOCUSING on ONE THING!

Leading Automation Data Acquisition Solution Provider

Contact Us

Sales Tel: +86-0816-2538289
Contact Email: sales@odotautomation.com
Technical Support: support@odotautomation.com
Address: 204 MianYang Comprehensive Bonded Zone, Hi-Tech District,
Eastern section of FeiYun Avenue, MianYang, Sichuan Province, China. 621000



Official Website



Twitter



LinkedIn



Odot Automation

Product Brochure

Remote I/O System · PLC · Protocol Converter · IIOT
Gateway · Industrial Switch



Sichuan Odot Automation System Co., Ltd.

Founded in 2003, ODOT Automation offers reliable, stable and bankable solutions to help you simplify your production process.

As a national high-tech enterprise, we are specializing in industrial communication product R&D, industrial automation control system design, integration and technical services. ODOT product has verification of EMC compliance "CE" and Quality Management system ISO9001:2015, we are also a member of PROFIBUS & PROFINET Association (PChina), EtherCAT Technology Association, CC-Link, OPC, CCIA, Industrial Internet Alliance and other associations.

ODOT has successfully provided professional field data collection solutions for intralogistics, lithium battery plant, AUTOs, New Energy, Wind Power, Textile enterprises, Automobile accessory enterprises, Cereal & oil processing enterprises, Food and Beverage producing enterprise, water treatment, power management, hydro power station, liquor producing enterprises etc.

We have built a long-term relationship and trust with our customers. We are always happy to provide value added services to beyond customer requirements and expectations.



Membership Certificate



Industry Application



Machinery Industry

- CNC
- Food & beverage
- Grain & oil machinery
- Smart factory
- AUTO



Energy Industry

- Thermal plant
- Hydropower station
- PTD
- Solar
- Photovoltaic-PV
- Lithium battery industry
- Wind power



Process Control

- Sewage disposal
- Oil & Gas
- Chemical
- Pharmacy



Other Industry

- Railway
- Urban rail
- Building
- HVAC
- Logistics sorting & transmission solutions

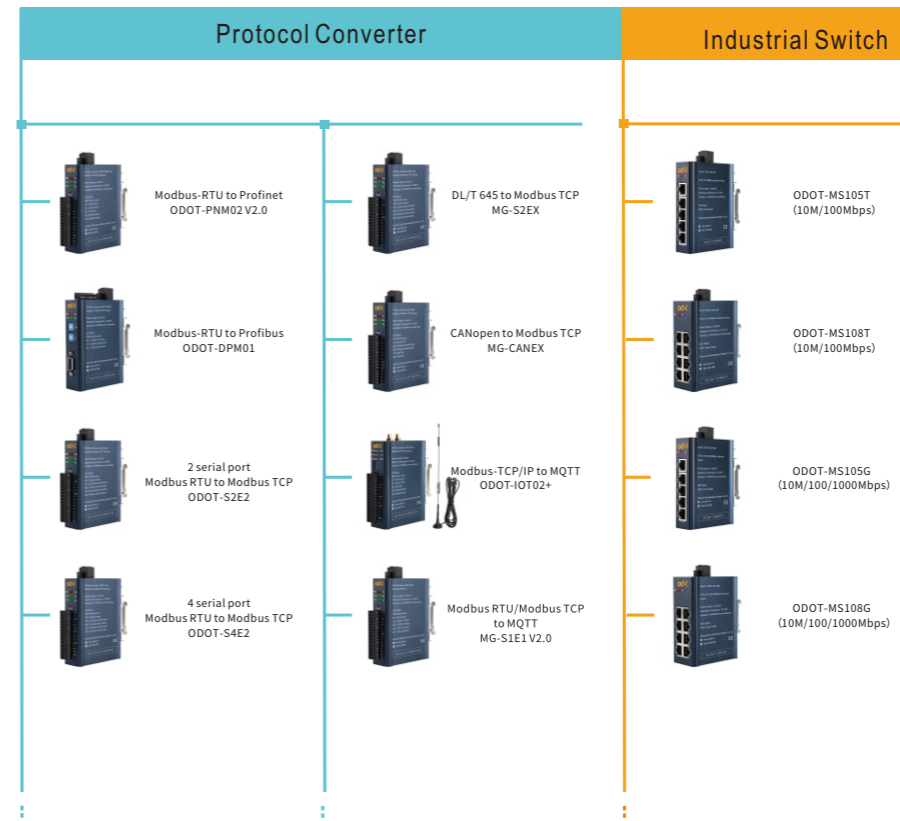
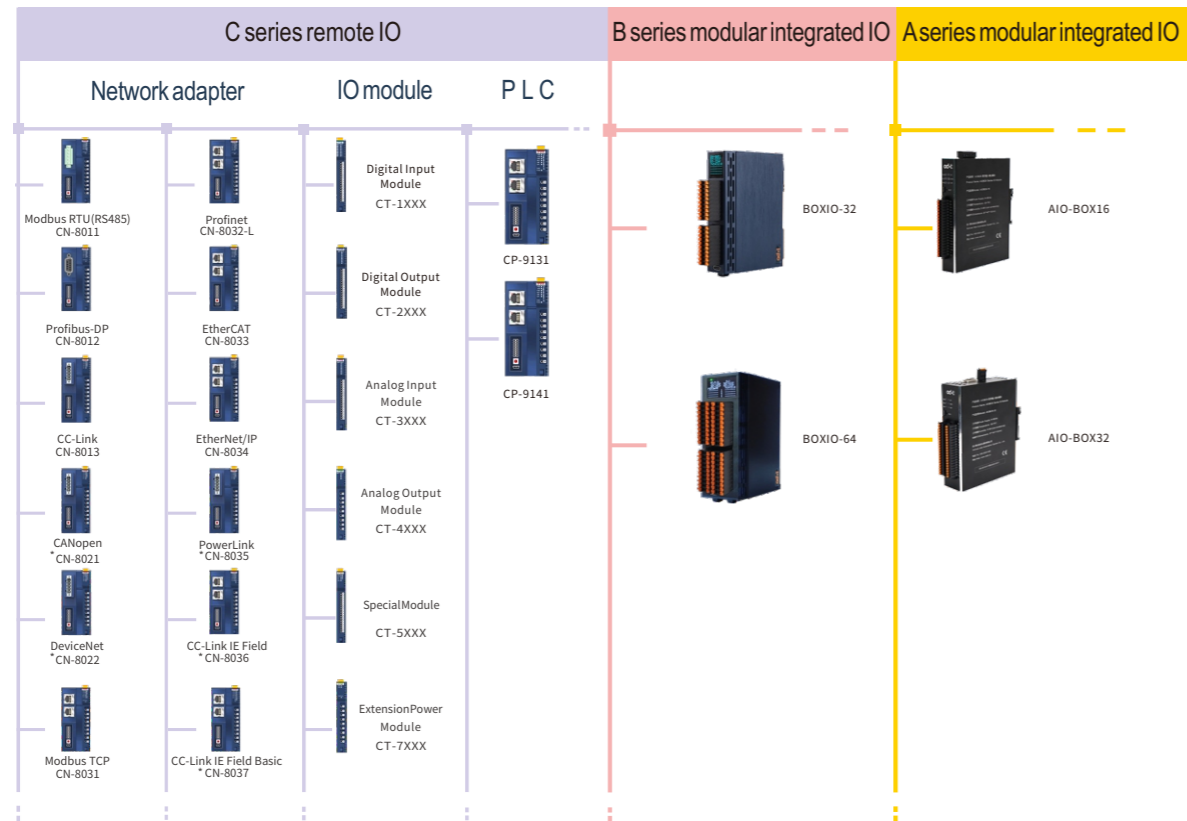

▶ C series remote IO system

C series – the remote IO consists of network adapter and extended IO module. The network adapter is responsible for fieldbus communication, and it could realize the communication with the master controller or host computer software.

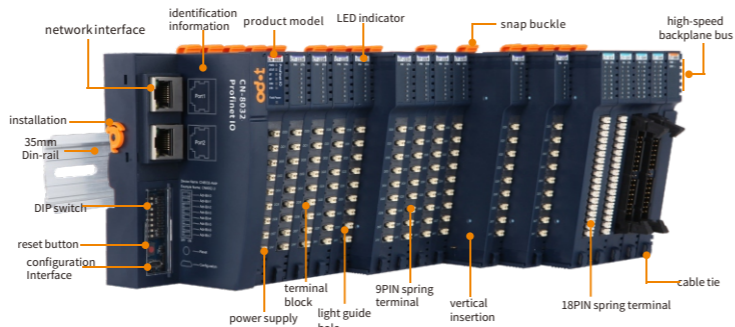

- ◆ The product carries ultra-thin design for space saving
- ◆ Spring terminal design for convenience and fast wiring
- ◆ Edged guide light terminal design.
- ◆ High-speed 12M CANBUS backplane carrying 64 digital quantity modules of a refreshing period at 2ms and analog modules at 3.4ms.
- ◆ The IO adapter could carry max of 32 pcs of IO modules
- ◆ PCB ODM service and tailored services for special module, special function customized.



Network adapter



IO module

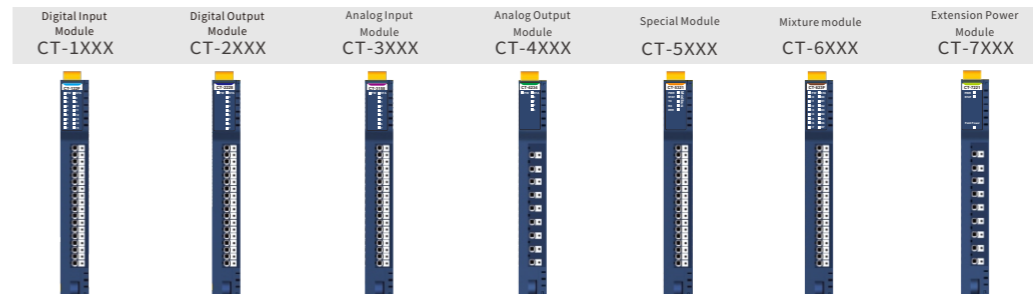

Network Adapter

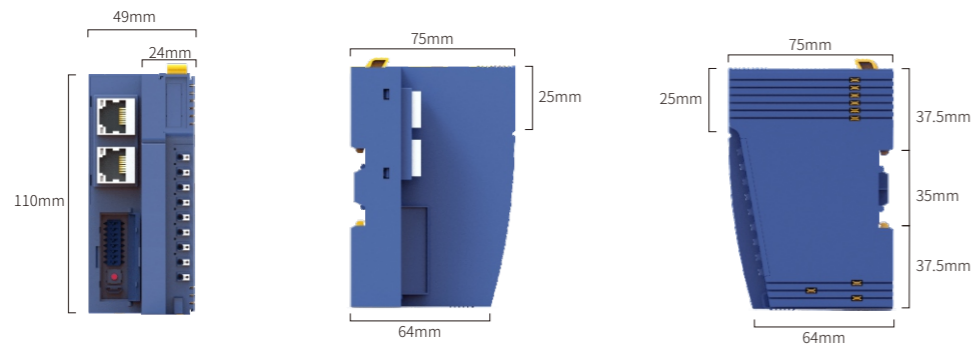

IO Modules&Terminal Module

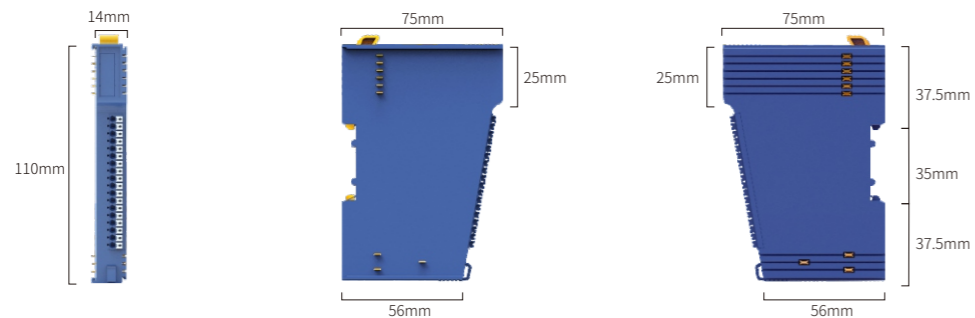

Backplane Bus Expansion Topology

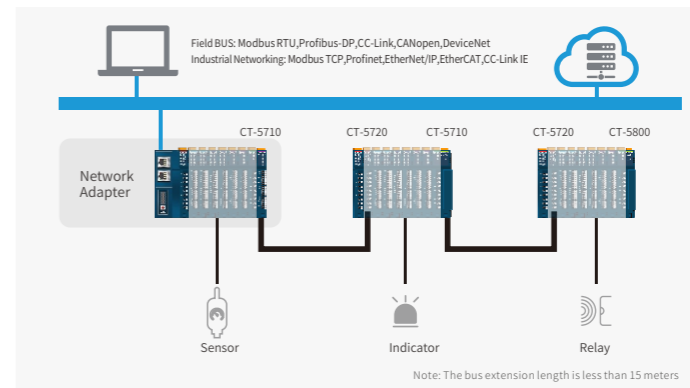

APPLIED TOPOLOGY

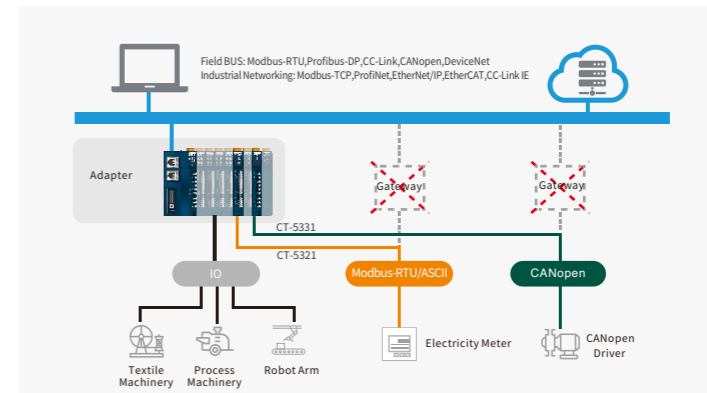

CT-5321 Master Application Topology

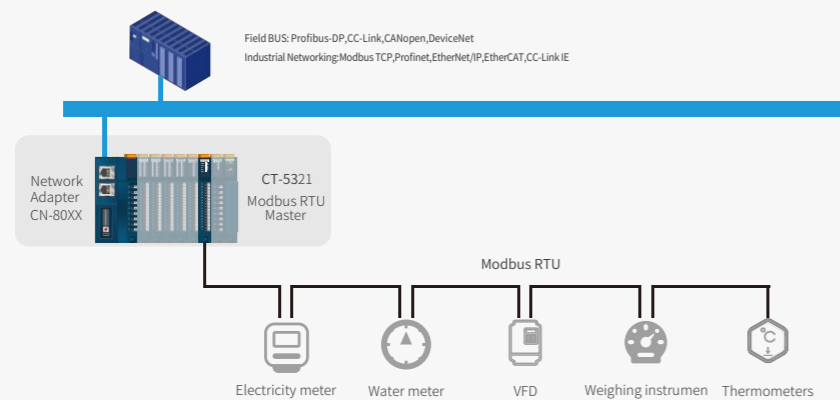

CT-5321 Slave Application Topology

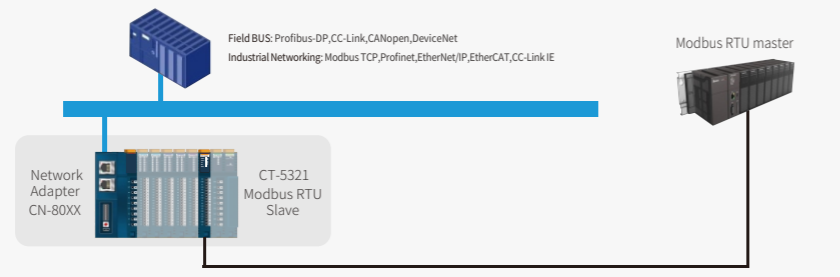

PLC

CP-9131

- ① Complied with IEC61131-3 standard
- ② Supports dual network (supports Modbus-TCP, ICMP, HTTP, DHCP and other protocols)
- ③ Supports OPC, MQTT
- ④ Mounted for ODOT C series IO modules
- ⑤ Programming tool: CODESYS V3.5 SPP16
- ⑥ Program storage: 2MBytes
- ⑦ Data storage: 2KBytes
- ⑧ Non-volatile location: 4Kbytes(Retain:2Kbytes,Flag:2Kbytes)
- ⑨ Programming language: IEC 61131-3(LD,IL,ST,FBD,SFC)
- ⑩ RTC:Accuracy:<2min/month
- ⑪ Type : Modbus TCP Server
- ⑫ Maximum number of expansion slots: 32 slots



CP-9141

- ① Complied with IEC 61499 standard
- ② Supports dual network , working power supply DC 24V
- ③ Mounted for ODOT C series IO modules
- ④ The control system consists of equipment and network
- ⑤ RTC:Accuracy:<2min/month
- ⑥ User applications can be deployed to run on different PLCs
- ⑦ Supports high-level language programming such as: C++, python, etc.
- ⑧ Supports OPC UA, MQTT and Modbus TCP
- ⑨ With event-driven function , suitable for interacting with IT systems
- ⑩ Adopts the design idea of object-oriented program and use the concept of function block to program
- ⑪ Multiple PLCs are combined to form a distributed control system.
The whole system only needs one time programming and one time download.
- ⑫ Maximum number of expansion IO slots: 32slots



B series Modular integrated IO

- ◆ BOXIO-32 carries 1 communication board and 2 IO slots, BOXIO-64 carries 1 communication board and 4 IO slots;
- ◆ The communication protocols with Modbus-TCP, Profinet, EtherCAT, EtherNet/IP are optional for the communication board;
- ◆ Slots 1/2/3/4 can be independently selected according to customer IO requirements, and a single module supports up to 16 channels;
- ◆ With LCD display, you can view information such as communication parameters, IO channel status, module version, etc.;
- ◆ Plastic shell, small size, easy to install;
- ◆ Independent design, can be customized by OEM and ODM;

BOXIO
B 32



BOXIO
B 64

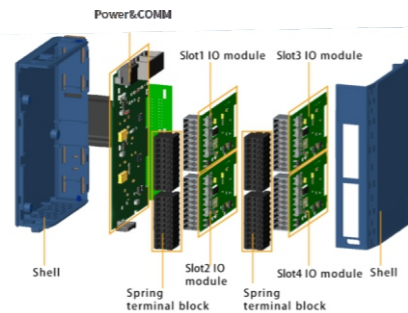
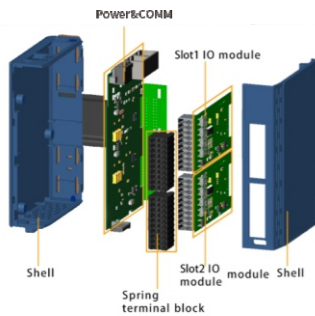

Selection table (Optional)

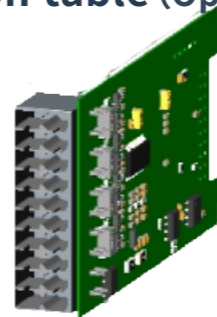

Power&COMM Board



Digital input module

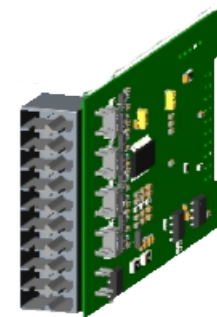

Digital output module

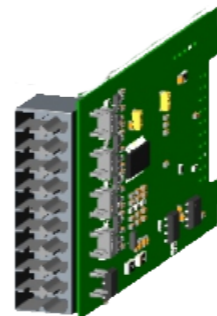

Analog input module



Analog output module

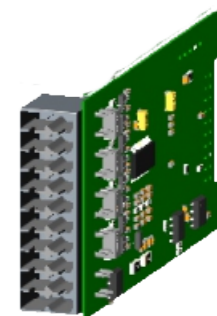

Mixture IO module

A series modular integrated IO



- ◆ AIOBOX-16 supports 3 slots, slot 0 for communication board, slot 1/2 for IO module;
- ◆ AIOBOX-32 supports 5 slots, slot 0 for communication board, slot 1/2/3/4 for IO module;
- ◆ The communication protocols with Modbus TCP/Modbus RTU, Profinet, EtherCAT, Profibus-DP and CANopen are optional for the communication board;
- ◆ Slot 1/2/3/4 can be selected according to customer needs, Max. 32 channels
- ◆ Working temperature: -40°C~85°C

IO Module

IO Modules (Max.2 IO for AIOBOX-16 and Max.4 for AIOBOX-32):

- AIO-X1248 8 channel / digital input / 24VDC / source or sink type
- AIO-X2228 8-channel / digital output / 24VDC / source type
- AIO-X3318 8-channel / single-ended / 0&4-20mA input, 16-bit
- AIO-X3424 4-channel/differential/0&4-20mA, ±20mA input, 16-bit
- AIO-X3713 3-channel / RTD-PT100 / input
- AIO-X3804 4-channel / TC thermocouple / input
- AIO-X6227 7-channel / 24VDC / digital composite module 4DI + 3DO
- AIO-X4312 2-channel 0-20/ 4-20/ 0-24mA current output 12 bytes
- AIO-X4314 4-channel 0-20/ 4-20/ 0-24mA current output 12 bytes
- AIO-X4322 2-channel 0-20/ 4-20/ 0-24mA current output 16 bytes
- AIO-X4324 4-channel 0-20/ 4-20/ 0-24mA current output 16 bytes
- AIO-X5102 2-channel/ Incremental encoder input/ 5V TTL input
- AIO-X5112 2-channel/ Incremental encoder input/ 1Vpp Sinusoidal input

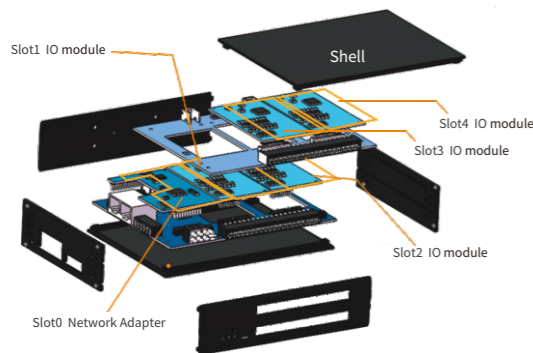

Communication module (Optional)

AIO-X8032(Profinet):

Adapter Type: PROFINET IO device
 Ethernet Port: 2 ports with switch function
 Speed: 10/100Mbps adaptive, Auto-MDI/MDIX
 Transmission Distance: Max.100m
 Data Length: Max.512 Byte input
 Max. 512 Byte output
 Isolation: Electromagnetic isolation

AIO-X8031(Modbus):

Ethernet Ports: 2 ports with switch function
 Adapter Type 1: Modbus-TCP Server
 Speed: 10/100Mbps adaptive, Auto-MDI/MDIX
 Transmission Distance: Max.100m
 Clients: Max. 2 clients at the same time
 Function Code: 01/02/03/04/05/06/15/16
 Isolation: Electromagnetic isolation
 Serial Port: 1 RS485
 Adapter Type 2: Modbus-RTU Slave
 Wiring: 3.81mm plug screw terminal
 ESD Protection: ±16KV
 Data Bits: 7, 8
 Stop Bits: 1, 2
 Check digit: None, even, odd
 Baud Rate: 2400~115200bps
 Function Code: 01/02/03/04/05/06/15/16
 Serial Mode: Supports RTU and ASCII

AIO-X8012(Profibus-DP):

Adapter Type: PROFIBUS-DP slave
 Protocol: PROFIBUS-DP/V0
 Ports: DB9 * 1
 Speed: 9.6K-12Mbps adaptive
 Data Length: Max. 244 Byte input
 Max. 244 Byte output
 Address Config: 8-bit dial code switch

AIO-X8021(CANopen):

Adapter Type: CANopen slave
 Protocol: CANopen DS 401
 Ports: DB9 * 1
 Speed: 10K-1Mbit/sec, adaptive
 Data Length: Max.512 Byte input
 Max. 512 Byte output
 Address Config: 8-bit dial code switch

AIO-X8033(EtherCAT):

Adapter Type: EtherCAT slave
 Ethernet Port: 2
 Speed: 10/100Mbps adaptive MDI/MDIX
 Transmission Distance: Max. 100m
 Data Length: Max.256 Byte input
 Max. 256 Byte output

▶ ODOT-PNM02 V2.0



ODOT-PNM02 V2.0 gateway is a Modbus-RTU/ASCII to PROFINET protocol converter. This product can connect Modbus device to PLC(S7-300/1200/1500/400) with PROFINET communication interface. It adopts aluminum alloy shell with firm design and supports DIN-rail installation. All serial signal provides built-in photoelectric isolation.

- ◆ Supports protocol conversion between Modbus and PROFINET
- ◆ Supports 2* RS485/RS232 or 1* RS422
- ◆ Supports Modbus master or slave, and supports RTU or ASCII
- ◆ Supports working temperature of -40~85°C
- ◆ Supports data area: 2 serial Modbus-RTU/ASCII to PROFIBUS gateway with Max. input 1440 bytes and Max. output 1440 bytes
- ◆ Supports one key reset

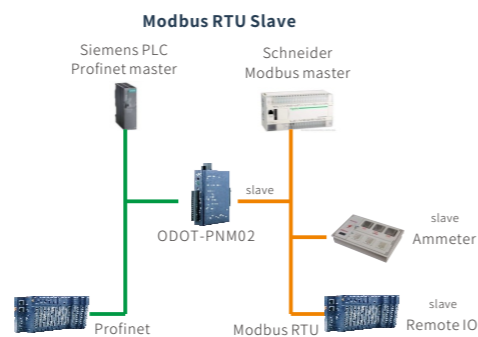
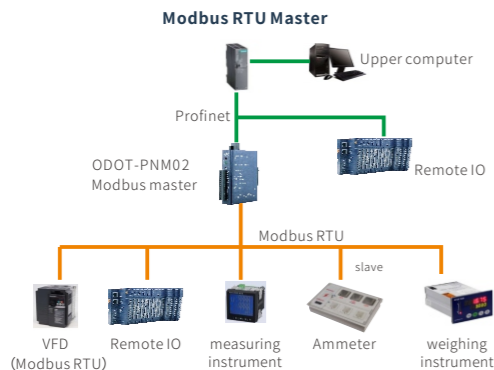

ODOT-DPM01

ODOT-DPM01 gateway is a Modbus-RTU/ASCII to PROFIBUS-DP protocol converter. This product can connect Modbus device to Siemens PLC(S7-300/1200/1500/400) with PROFIBUS-DP communication interface or DCS system with DP master. It adopts aluminum alloy shell with firm design and supports DIN-rail installation. All serial signal provides built-in photoelectric isolation.

- ◆ Supports protocol conversion between Modbus and PROFIBUS
- ◆ Supports RS485, RS422 and RS232
- ◆ Supports Modbus master and slave, and supports RTU or ASCII
- ◆ Supports working environment of -40~85°C
- ◆ PROFIBUS-DP: Max. input 244 bytes, Max. output 244 bytes
- ◆ DPM01: 1-way Modbus to PROFIBUS slave gateway, sum of input and output is 288 bytes.
- ◆ DPM02: (customization) 1-way Modbus-RTU to PROFIBUS slave gateway, sum of input and output is 488 bytes.

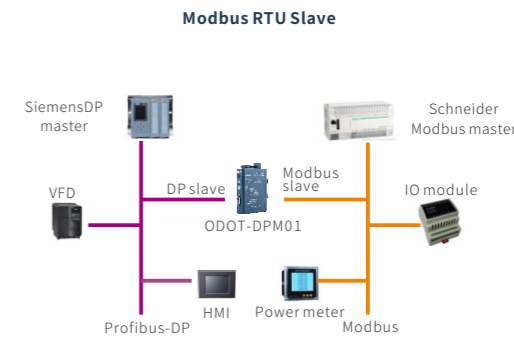
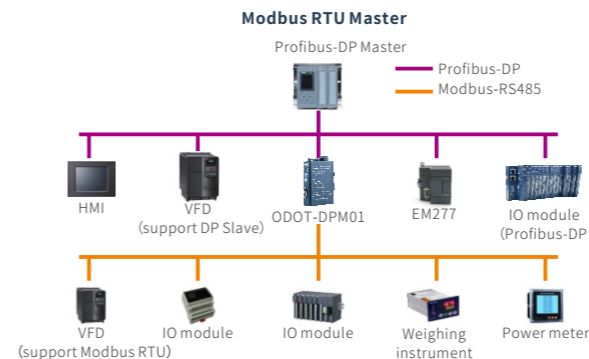

▶ ODOT-S2E2/S4E2



- ◆ Supports protocol conversion between Modbus-RTU and Modbus-TCP
- ◆ Supports the connection of 5 TCP clients simultaneously
- ◆ ODOT-S2E2 supports 2*RS485
- ◆ ODOT-S4E2 supports wiring of RS485/RS232/RS422
- ◆ Each serial port supports Modbus master and slave
- ◆ ODOT-S2E2: 2 serial Modbus-RTU/ASCII to Modbus-TCP Server gateway
- ◆ ODOT-S4E2: 4 serial Modbus-RTU/ASCII to Modbus-TCP Server gateway
- ◆ Supports one key reset
- ◆ Gateway working mode: Transparent transmission, address mapping

ODOT-S2E2/S4E2 gateway is a Modbus-RTU/ASCII to Modbus-TCP protocol converter. This product can connect Modbus device to PLC and master computer that support Modbus-TCP (client) functions. It supports the connection of 5 TCP clients simultaneously. And product adopts aluminum alloy shell with firm design and supports DIN-rail installation. All serial signal provide built-in photoelectric isolation.

Typical application topology

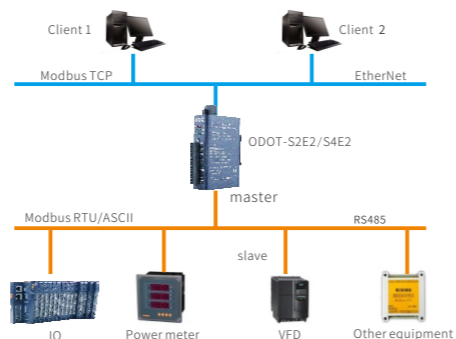

MG-S2EX

- ◆ Supports protocol conversion between Modbus and Modbus-TCP
- ◆ Supports protocol conversion between DL/T 645 and Modbus-TCP
- ◆ Supports protocol conversion between DL/T 645 and Modbus-RTU
- ◆ Support three Modbus modes
- ◆ The 2007 edition can collect 65 datas from a single table, while the 1997 edition can collect 42 datas
- ◆ Power meter data type: 64-bit floating point or 64-bit long integer
- ◆ 16KB data storage area
- ◆ 1 port Modbus-RTU to Modbus-TCP Server gateway
- ◆ 1 port DL/T 645 to Modbus-TCP Server gateway
- ◆ Supports One-Key reset function



Typical application topology

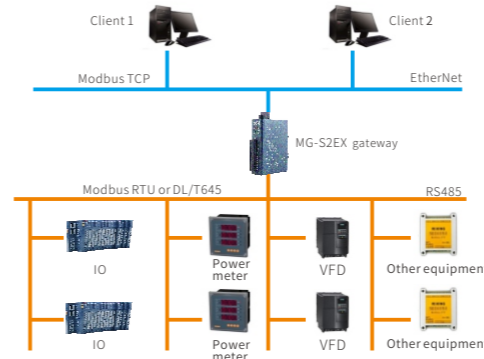

MG-S2EX gateway is a Modbus-RTU and DL/T 645 to Modbus-TCP protocol converter. The product can connect Modbus devices and DL/T 645 devices to PLC and host computers that support Modbus-TCP client, and supports 5 Modbus-TCP client' s connections at the same time. The product adopts metal shell, strong design, support Din-rail installation, serial port signals are provided with built-in photoelectric isolation.

MG-CANEX



- ◆Dual Ethernet port with switch function, support cascade
- ◆2KV network port isolation protection, 10M/100Mbps rate adaptive, (Auto-MDI/MDIX)
- ◆Supports address mapping mode, to achieve rapid response to TCP client requests
- ◆Supports up to 10 TCP clients accesses
- ◆6KB large data cache area, more data transfer
- ◆CAN interface supports CANopen, CAN2.0A and CAN2.0B
- ◆Equipped with powerful diagnostic function, real-time monitoring of communication status from the slave device
- ◆Supports One-Key reset function, restore to factory settings
- ◆EMC complies with EN 55022:2010 & EN55024:2010 international standards introduction.

MG-CANEX is a protocol converter that CANopen to Modbus TCP/IP. The device acts as the Master in the CANopen network, with NMT network management function, and can be connected by standard CANopen slave devices. Supports the PDO, SDO data transmission, Error-Control supports Node Guarding, Heartbeat. Supports synchronous message sending. As a TCP server in Modbus-TCP/IP network, the device can be accessed by multiple TCP clients at the same time, and can access to PLC controller and various host configuration softwares. It can connect to the optical terminal and other equipment to realize long-distance data transmission.

Typical application topology

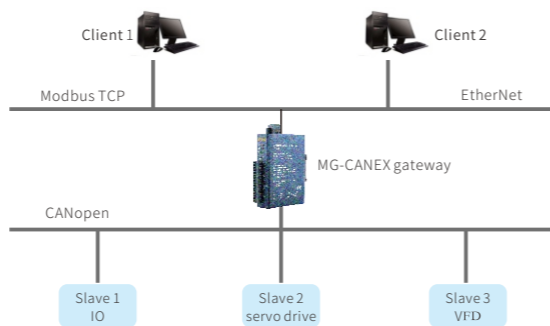

MG-IOT02+

New industrial IoT gateway

- ◆2 Ethernet Ports, with switch function, supports cascade
- ◆2KV Ethernet Port isolation protection, 10M/100Mbps rate adaptation, (Auto-MDI/MDIX)
- ◆Supports connection to Modbus-RTU/ASCII protocol
- ◆Supports simultaneous connection of 5 Modbus-TCP/IP clients
- ◆Supports 200 collection points
- ◆Supports MQTT connection to cloud, ethernet port and 4G to cloud optional
- ◆Supports data sort exchange and data type conversion
- ◆Supports data calculation
- ◆Supports IAP download, through the ethernet port to update the firmware program in the product
- ◆EMC complies with EN 55022:2010 & en55024:2010 international standards.



Typical application topology

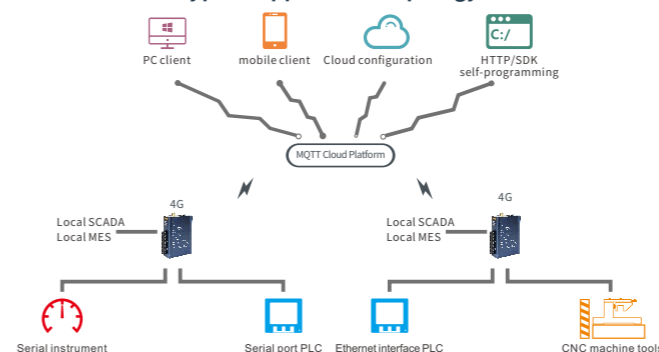

MG-IOT02+ is a protocol converter from Modbus-RTU to Modbus-TCP/IP and MQTT. All devices with RS485/RS422/RS232 interface can be connected to Modbus-TCP/IP network through this converter. In this way, low-speed serial port devices can be connected to high-speed Ethernet and cloud servers, so as to realize the function of industrial data collection, and meanwhile support the connection to cloud platform through 4G network MQTT.

▶ ODOT-S1E1 V2.0



- ◆ Supports TCP server and TCP client transparent transmission
- ◆ Supports UDP transparent transmission and virtual serial ports
- ◆ Supports transparent transmission with or without protocol. Protocol transparent transmission supports MODBUS RTU/ASCII
- ◆ Supports WEB browser configuration parameters (Common parameters)
- ◆ Serial port baud rate 1200 to 115200 bps
- ◆ Supports transparent transmission through MQTT

Typical application topology

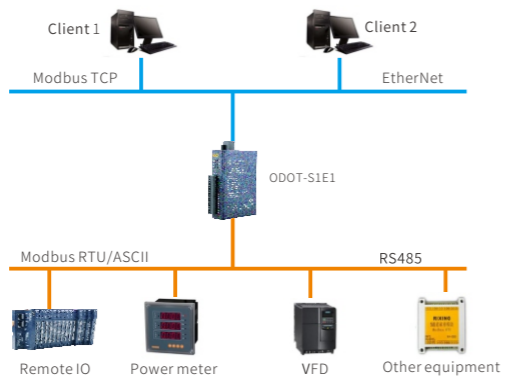

ODOT-MS100T/G system

ODOT-MS100T Industrial-grade unmanaged Ethernet switch,

- ◆ 10/100 Mbps self-adaption (Auto-MDI/MDI-X)
- ◆ All supports IEEE802.3/802.3u/802.3x/802.3z
- ◆ Supports broadcast storm protection
- ◆ Working temperature range: -20~70°C;
- ◆ 5/8/16 ports unmanaged Ethernet Switches DIN-rail

ODOT-MS105T: 5-port 10/100Mbps, 35mm DIN-rail
 ODOT-MS108T: 8-port 10/100Mbps, 35mm DIN-rail
 ODOT-MS116T: 16-port 10/100Mbps, 35mm DIN-rail
 ODOT-MS105G: 5-port 10/100/1000Mbps, 35mm DIN-rail
 ODOT-MS108G: 8-port 10/100/1000Mbps, 35mm DIN-rail



Typical application topology

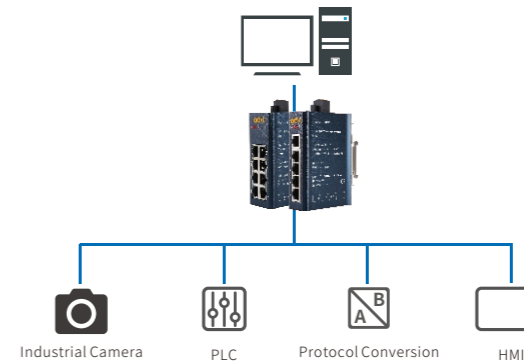

IO application in logistics industry



At present, the logistics sector is divided into three categories: warehousing system, expressing system and e-commerce system. The logistics list in recent years shows that, the express business volume in China during the "11. 11 shopping festival " period reached 6.8 billion parcels, and the global express logistics industry has also continued to grow. Sorting is one of the most labor-intensive and labor-intensive links in the entire logistics industry.

Using the automatic sorting system to complete the sorting of logistics parcels plays a huge role in improving the efficiency of logistics operations. Our customer use the Linear Cross Belt Sorting System with ODOT C series remote IO systems, which can quickly, efficiently and accurately realize parcel sorting.

Solution:

The field uses the Siemens PLC S7-1200,1500,(Upper software WMS). After the preliminary sample test, ODOT CN-8032-L Profinet network adapter will straight replacing siemens IO system, ODOT digital input module (CT-121F 16DI ,24VDC,PNP) and digital output module(CT-222F,16DO PNP,24VDC) are it mostly used in the project,

IO module is connected to the on-site sensors, actuators, collects data and analyzes data through PLC, and carries out fast, efficient and accurate sorting on site.



Highlights:

1. Using ODOT C series distributed remote I/O system can solve the problem of large number of warehouse spaces and unreasonable layout, and realize decentralized management and centralized control.
2. Saving cost, C series distributed remote I/O is more cost-effective .
3. Customer Feedback : Convenient installation | Affordable | Space-Saving | Stable.



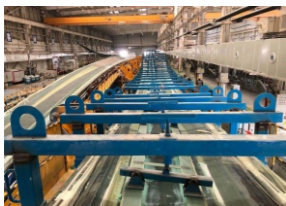

As a kind of green energy, wind energy belongs to a new type of environmental protection and energy saving new energy. Besides water energy, wind energy has become one of the energy sources with the most mature technology, the most conditions for large-scale development and commercial development prospects.

A Project Overview in Jiangsu Province China, some components of its wind turbine generator, such as generators, IGBTs, filter capacitors and pitch motors, will generate heat during the power generation process. In order to ensure the normal operation of the generator set, there are a large number of temperature sensors PT100 on site. These sensors require a stable and reliable (high temperature resistance, vibration resistance, anti-condensation) acquisition device to collect on-site temperature data. The temperature data is uploaded to the control room through the network, and then the system controls the operation of the on-site cooling system.



Solution:

The AIO series IO products of ODOT can adopts industrial-grade design, wide temperature(-40~85°C) and wide pressure design, and special rail installation, meets the customer's site high temperature resistance, vibration resistance, anti-cohdensation and other special requirements. The module supports a variety of protocols to communicate with the upper system, and the construction is fast and the network structure is simple. The solution help customer solved the issues of wind power cooling system, stability, and reduce maintenance costs. At present, AIO series IO has been fully used in this type of wind power projects, and it has been running for 5 years.

Highlights:

- 1.Using ODOT AIO series integrated I/O system can solve the problem of large number of warehouse spaces and unreasonable layout, and realize decentralized management and centralized control. industrial-grade design, wide temperature(-40~85°C), which could be used for small project.
- 2.AIO series integrated I/O system is cost-effective and low maintenance costs
- 3.Customer Feedback : Convenient installation | Affordable | Space-Saving | Stable



Types of Customers	Field-Grade	Industry Application	Use of ODOT product	Product Type	Application Projects	Project Pionts	Application Highlights	Achievement
Equipment manufacturer	Leading enterprises in the food and medical industry	Food	ODOT-PNM02	Gateway	Pharmaceutical machine in biological engineering project	Siemens PLC with communication module to connect limited slaves, if it requires more slaves and it will need to program the polling.	It could realize serial port communication via configuration. The serial port communication is simple and efficient.	It could realize the communication with serial port equipment via ODOT-PNM02.
	Lithium industry, coating, roller points	lithum battery	CN-8013,CN-8012, CT-121F CT-222F, CT-3238.CT-4154 CT-4158	Distributed IO	coating, roller points	The controllers of major overseas brands are in seriously short of supplying.And it has servely influenced the production and lead time.	ODOT C series remote IO, it could support various kinds of protocols. The main stream controllers in the market could be matched corresponding protocol adapters, with a rich submodule category.	Customer shifted overseas brands to ODOT C series los perfectly.
	CNC MACHINE	Steel processing industry	CN-8033 CT-221F CT-121F CT-122F CT-2718	Distributed I/O	CNC equipment	Customer seek a cost-effective alternative to Omron	ODOT remote IO system covering protocols (Porfinet Porfbus-DP EtherCAT EtherNET/IP Modbus TCP Modbus RTU CC-LINK, etc.)which can meet customer needs	ODOT CN-8033 EtherCAT successfully replaced the Omron IO
System Integrator	Leading enterprises in the sorting industry	logistic sorting	CN-8032-L CT-121F,CT-222F	Remote I/O system	Logistics sorting line and Linear Cross Belt Sorting System	We provided alternative solutions as the Siemens brand is in short of supplying as we have good lead time with sufficient stock.	The technical parameters of controller and its sub-module could meet customer control requirements.	ODOT I/O system has successfully replaced the main bus protocol products on the market
	Auto parts	Automative	CN-8032-L CT-121F CT-222F CT-3238	Remote I/O system	Equipment and System Integrator	Chips shortage in supplying , IO system Totally out of stock	Self-developed PN protocol soft protocol stack to get rid of the dependence of PN protocol on special chips. The soft protocol station technology is used on C series distributed IO to produce CN-8032-L	CN-8032-L has successfully realized the replacement of CN-8032, running stably and meeting customer needs and Able to long-term supplying.
	The largest casting machine manufacturer	die-casting	CN-8032-L CT-121F CT-222F CT-3238 CT-4234, CT-5112	Remote I/O system	die-casting machinery	Chip shortage leads to control system of IO system The total shortage of stock has also led to the infinite extension of the delivery period of the control system and IO system.	The CN-8032-L developed based on the self-developed PN protocol soft protocol stack runs stably, Get rid of the dependence on special chips, sufficient supply. Completely localized and cost-effective	CN-8032-L has successfully realized the replacement of CN-8032, running stably and meeting customer needs and Able to long-term supplying.
	CRRC wind power company	WIND POWER	A32-MT5555/A32-MT555	AIOBOX	Fan temperature measurement system	The customer's application scene is harsh, Our company has made an upgrade with reference to other EtherCAT product technical parameters, and is now used for stable and reliable products.	Solved the supply problem for customers and shortened the leading time	ODOT CN-8033 EtherCAT successfully replaced the Beckhoff IO module